

IP20 SELV 

### Driver LCI 65 W 1400/1750 mA TEC C

TEC series

#### Product description

- Fixed output built-in LED Driver
- Constant current LED Driver
- Output current 1,400 or 1,750 mA
- Max. output power 65 W
- Nominal life-time up to 50,000 h
- For luminaires of protection class I and protection class II
- Temperature protection as per EN 61347-2-13 C5e
- 5-year guarantee

#### Housing properties

- Casing: polycarbonat, white
- Type of protection IP20

#### Functions

- Overtemperature protection
- Overload protection
- Short-circuit protection
- No-load protection

#### Technical data

Rated supply voltage	220 – 240 V
AC voltage range	198 – 264 V
Current at 50 Hz 230 V	0.32 A
Mains frequency	50 / 60 Hz
Overvoltage protection	300 V AC, 1 h
Typ. power consumption (at 230 V, 50 Hz, full load)	72 W
Max. input power	75 W
Output power	65 W
THD (at 230 V, 50 Hz, full load)	< 20 %
Output current tolerance <sup>®</sup>	± 7.5 %
Typ. current ripple (at 230 V, 50 Hz, full load)	± 30 %
Starting time (at 230 V, 50 Hz, full load)	≤ 0,7 s
Turn off time (at 230 V, 50 Hz, full load)	≤ 0,7 s
Hold on time at power failure (output)	0 s
Ambient temperature $t_a$	-20 ... +50 °C
Ambient temperature $t_a$ (at life-time 50,000 h)	40 °C
Max. casing temperature $t_c$	95 °C
Storage temperature $t_s$	-40 ... +80 °C
Life-time	up to 50,000 h
Dimensions L x W x H	123 x 75 x 29.7 mm

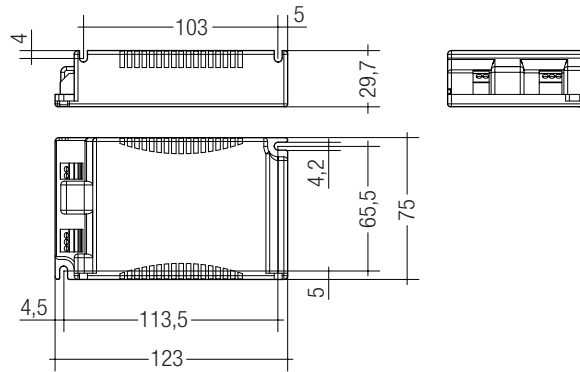

#### Ordering data

Type	Article number	Packaging, carton	Packaging, low volume	Packaging, high volume	Weight per pc.
LCI 65W 1400mA TEC C	87500204	30 pc(s).	450 pc(s).	2,250 pc(s).	0188 kg
LCI 65W 1750mA TEC C	87500206	30 pc(s).	450 pc(s).	2,250 pc(s).	0189 kg



**Standards**, page 2

**Wiring diagrams and installation examples**, page 3

**Specific technical data**

Type	Output current <sup>①</sup>	$\lambda$ at full load <sup>②</sup>	Efficiency at full load <sup>③</sup>	$\lambda$ at min. load <sup>②</sup>	Efficiency at min. load <sup>③</sup>	Min. forward voltage <sup>②</sup>	Max. forward voltage <sup>②</sup>	Max. output voltage	Max. peak output current at full load <sup>②③</sup>	Max. peak output current at min. load <sup>②③</sup>
<b>LCI 65W 1400mA TEC C</b>	1,400 mA	0.98	90 %	0.93	88.5 %	23.0 V	46.5 V	55 V	1,960 mA	2,340 mA
<b>LCI 65W 1750mA TEC C</b>	1,750 mA	0.98	90 %	0.93	87.5 %	18.5 V	37.0 V	43 V	2,450 mA	2,950 mA

① Test result at 230 V, 50 Hz.

② The trend between min. and full load is linear.

③ Output current is mean value.

**Standards**

EN 55015  
EN 61000-3-2  
EN 61000-3-3  
EN 61347-1  
EN 61347-2-13  
EN 61547  
EN 62384

Housing fulfils requirements for reinforced insulation according EN 60598-1.

**Overload protection**

If the output voltage range is exceeded the LED Driver reduces the LED output current. After elimination of the overload the nominal operation is restored automatically.

**Overtemperature protection**

The LED Driver is protected against temporary thermal overheating. If the temperature limit is exceeded the output current is reduced to limit  $t_c$  at a certain level. The temperature protection is activated typically at 8 °C above  $t_c$  max.

**Short-circuit behaviour**

In case of a short circuit on the secondary side (LED) the LED Driver switches into hic-cup mode. After the removal of the short-circuit fault the LED Driver will recover automatically.

**No-load operation**

The LED Driver works in constant voltage mode. In no-load operation the output voltage will not exceed the specified max. output voltage (see page 1).

**Expected life-time**

Type	$t_a$	40 °C	50 °C	60 °C
<b>LCI 65W xxxmA TEC C</b>	$t_c$	85 °C	95 °C	x
	Life-time	50,000 h	30,000 h	x

The LED Drivers are designed for a life-time stated above under reference conditions and with a failure probability of less than 10 %.

**Glow-wire test**

Glow-wire test according to EN 61347-1 with increased temperature of 850 °C passed.

**Mounting of device**

Max. torque for fixing: 0.5 Nm/M4

**Conditions of use and storage**

Humidity: 5 % up to max. 85 %  
not condensed  
(max. 56 days/year at 85 %)

Storage temperature: -40 °C up to max. +80 °C

The devices have to be within the specified temperature range ( $t_a$ ) before they can be operated.

**Installation instructions**

The LED module and all contact points within the wiring must be sufficiently insulated against 5.0 kV surge voltage.  
Air and creepage distance must be maintained.

**Replace LED module**

1. Mains off
2. Remove LED module
3. Wait for 10 seconds
4. Connect LED module again

Hot plug-in or secondary switching of LEDs is not permitted and may cause a very high current to the LEDs.

**Maximum loading of automatic circuit breakers in relation to inrush current**

Automatic circuit breaker type	C10	C13	C16	C20	B10	B13	B16	B20	Inrush current	
Installation Ø	15 mm <sup>2</sup>	15 mm <sup>2</sup>	15 mm <sup>2</sup>	25 mm <sup>2</sup>	15 mm <sup>2</sup>	15 mm <sup>2</sup>	15 mm <sup>2</sup>	25 mm <sup>2</sup>	$I_{max}$	Time
<b>LCI 65W 1400mA TEC C</b>	20	30	40	50	16	24	32	40	13 A	50 µs
<b>LCI 65W 1750mA TEC C</b>	20	30	40	50	16	24	32	40	13 A	50 µs

This are max. values calculated out of inrush current! Please consider not to exceed the maximum rated continuous current of the circuit breaker. Calculation uses typical values from ABB series S200 as a reference. Actual values may differ due to used circuit breaker types and installation environment.

**Harmonic distortion in the mains supply (at 230 V / 50 Hz and full load) in %**

	THD	3.	5.	7.	9.	11.
<b>LCI 65W 1400mA TEC C</b>	20	11	3	2	1	1
<b>LCI 65W 1750mA TEC C</b>	20	11	2	3	1	1

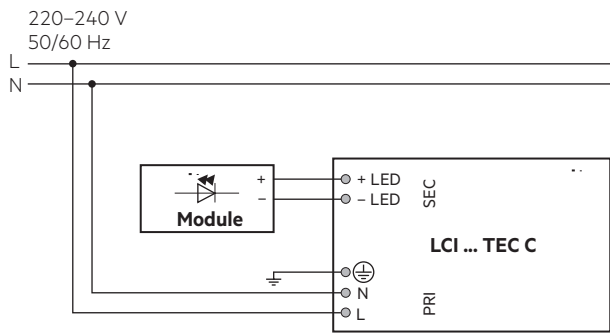
**Wiring diagram****Insulation and electric strength testing of luminaires**

Electronic devices can be damaged by high voltage. This has to be considered during the routine testing of the luminaires in production.

According to IEC 60598-1 Annex Q (informative only!) or ENEC 303-Annex A, each luminaire should be submitted to an insulation test with 500 V<sub>DC</sub> for 1 second. This test voltage should be connected between the interconnected phase and neutral terminals and the earth terminal. The insulation resistance must be at least 2 MΩ.

As an alternative, IEC 60598-1 Annex Q describes a test of the electrical strength with 1500 V<sub>AC</sub> (or 1.414 x 1500 V<sub>DC</sub>). To avoid damage to the electronic devices this test must not be conducted.

**Maximum number of switching cycles**

All LED Driver are tested with 50,000 switching cycles. The actually achieved number of switching cycles is significantly higher.

**Additional information**

Additional technical information at [www.tridonic.com](http://www.tridonic.com) → Technical Data

Guarantee conditions at [www.tridonic.com](http://www.tridonic.com) → Services

Life-time declarations are informative and represent no warranty claim. No warranty if device was opened.

**Wiring type and cross section**

The wiring can be stranded wires with ferrules or rigid wires with a cross section of 0.5 – 1.5 mm<sup>2</sup>.

Strip 8.5 – 9.5 mm of insulation from the cables to ensure perfect operation of the push-wire terminals (WAGO 250).

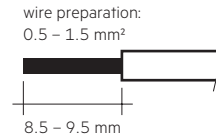
**Wiring instructions**

- All connections must be kept as short as possible to ensure good EMI behaviour
- Mains leads should be kept apart from LED Driver and other leads (ideally 5 – 10 cm distance)
- The maximum length of output wires is 2 m.
- Secondary switching is not permitted.
- Incorrect wiring can damage LED modules.
- To avoid the damage of the Driver, the wiring must be protected against short circuits to earth (sharp edged metal parts, metal cable clips, louver, etc.).

**Release of the wiring**

Press down the “push button” and remove the cable from front.

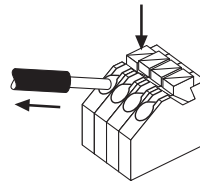

**Diagrams LCI 65W 1,400mA TEC C**

Efficiency vs Load

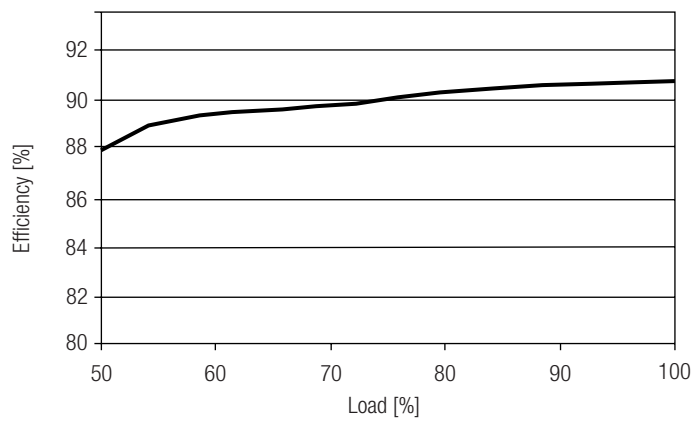

Power factor vs Load

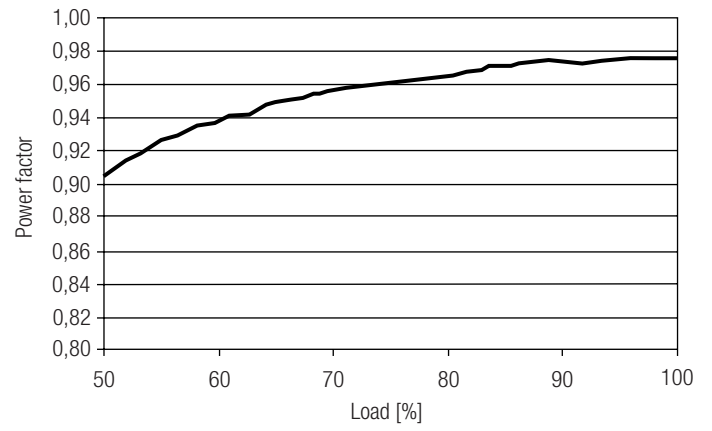

THD vs Load

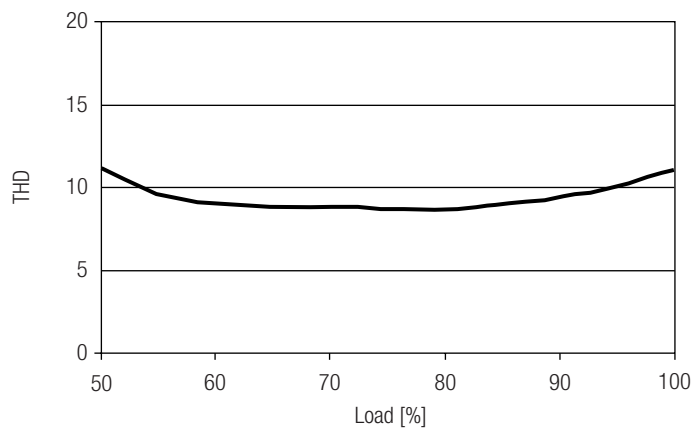

**Diagrams LCI 65W 1,750mA TEC C**

Efficiency vs Load

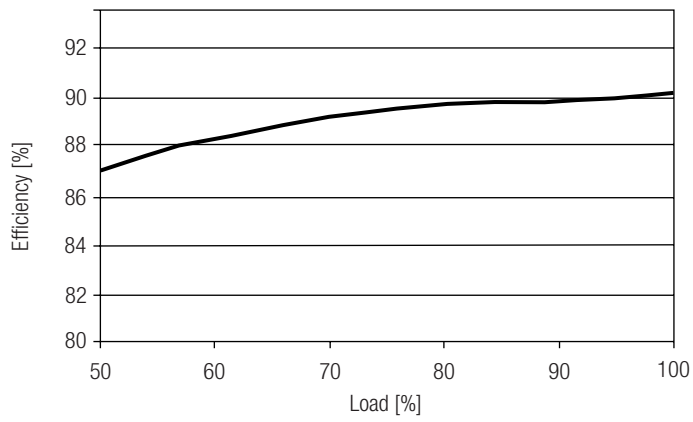

Power factor vs Load

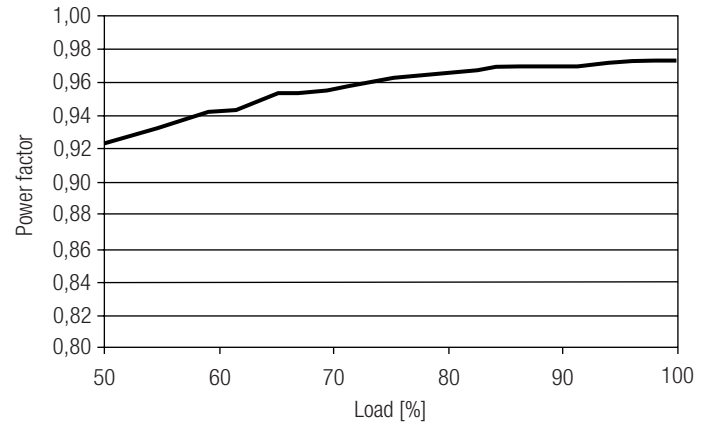

THD vs Load

