

IP20 SELV       

Driver LCI 30 W 700 mA IP20
TEC series

Product description

- Constant current LED Driver
- Universal input voltage range
- Constant output current 700 mA
- Strain relief
- Screw terminal
- 5-year guarantee

Properties

- High efficiency
- Low power loss
- Overtemperature protection
- Overload protection with automatic restart
- Short-circuit shutdown feature with automatic restart
- Protection class 2, SELV
- Type of protection IP20
- Casing: polycarbonate, white

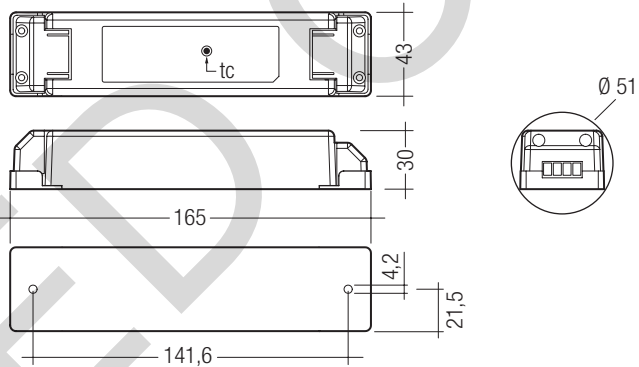

Technical data

Rated supply voltage	120 – 240 V
AC voltage range	108 – 264 V
DC voltage range	120 – 240 V
Rated current (at 230 V 50 Hz)	0.16 A
Mains frequency	50 / 60 Hz
Efficiency	> 80 %
Max. input power	35 W
λ (at 230 V 50 Hz)	> 0.95
Starting time (output)	\leq 0.5 s
Turn off time (output)	\leq 1 s
Hold on time at power failure (Output)	10 ms
Output current tolerance [Ⓢ]	\pm 8 %
Output current ripple	\pm 43 %
Max. repetitive output peak current	1,100 mA
Max. non-repetitive output peak current	1,100 mA
Max. output voltage [Ⓢ]	48 V
Output power	30 W
Ambient temperature t_a	-25 ... +50 °C
Ambient temperature t_a (at life-time 50,000 h)	-25 ... +40 °C
Max. casing temperature t_c	75 °C
Storage temperature	-30 ... +85 °C
Life-time	up to 50,000 h
Dimensions LxWxH	165 x 43 x 30 mm
Hole spacing D	142 mm

Ordering data

Type	Article number	Packaging carton	Packaging pallet	Weight per pcs.
LCI 030/0700 E020	24166314	40 pc(s).	2,000 pc(s).	0.2 kg

Specific technical data

Type	Output current [Ⓢ]	Output voltage range
LCI 030/0700 E020	700 mA	21 – 43 V

[Ⓢ] In non-load operation.

[Ⓢ] Output current is mean value.

Standards

- EN 55015
- EN 61000-3-2
- EN 61000-3-3
- EN 61347-1
- EN 61347-2-13
- EN 61547
- EN 62384

Installation instructions

Please note that LCI 030/0700 E020 complies with protection class II so special measures are needed if it is to be installed in protection class I applications / luminaires.

Please note the requirements set out in the document LED_driver_installation_advise.pdf (<http://www.tridonic.com/com/en/technical-docs.asp>).

Over temperature protection

Automatic shutdown of the LED Driver if the temperature limit is exceeded. Automatic restart if the temperature falls below the limit.

Overload protection

Automatic shutdown of the LED Driver if the maximum output voltage is exceeded. Automatic restart if the output voltage is below the limit.

Glow wire test according to EN 60695-2-11

850 °C passed.

Mounting of device

Max. torque for fixing: 0.5 Nm/M4

Maximum loading of automatic circuit breakers in relation to inrush current

Automatic circuit breaker type	C10	C13	C16	C20	B10	B13	B16	B20	Inrush current
Installation Ø	1.5 mm ²	1.5 mm ²	1.5 mm ²	2.5 mm ²	1.5 mm ²	1.5 mm ²	1.5 mm ²	2.5 mm ²	I _{max} time
LCI 030/0700 E020	60	90	120	140	30	45	60	70	80 A 0.001ms

This are max. values calculated out of inrush current! Please consider not to exceed the maximum rated continuous current of the circuit breaker. Calculation uses typical values from ABB series S200 as a reference. Actual values may differ due to used circuit breaker types and installation environment.

Efficiency versus load

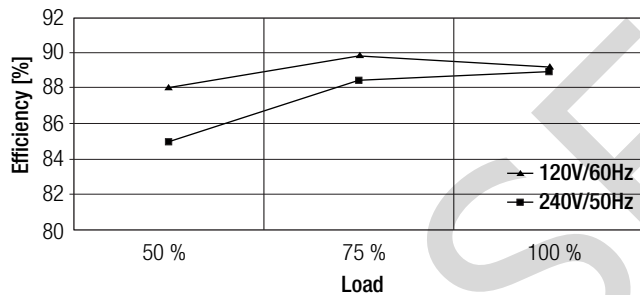

PF value versus load

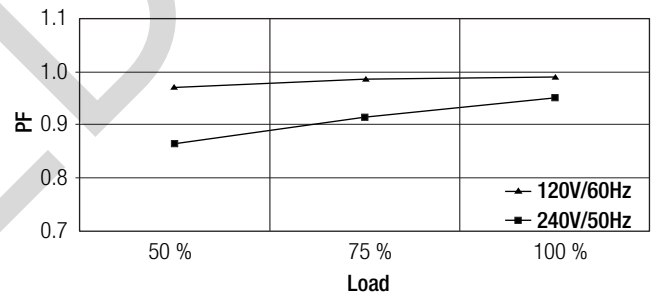

Wiring diagram

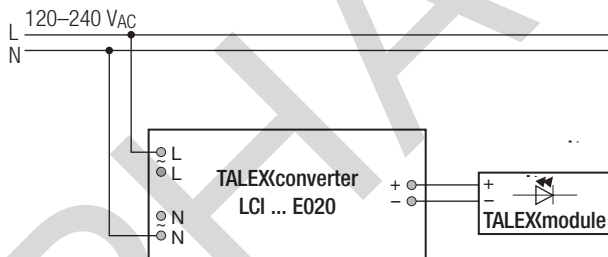

Installation instructions

The switching of LEDs on secondary side is not permitted.

Wiring guidelines

- All connections must be kept as short as possible to ensure good EMI behaviour.
- Mains leads should be kept apart from LED Driver and other leads (ideally 5 – 10 cm distance)
- Max. length of output wires is 2 m.
- Incorrect wiring can damage LED modules.
- To avoid the damage of the Driver, the wiring must be protected against short circuits to earth (sharp edged metal parts, metal cable clips, louver, etc.).

Wiring type and cross section

The wiring can be in stranded wires with ferrules or solid. For perfect function of the screw terminals the strip length should be 7.5–8.5 mm for the terminal.

Input / Output terminal

PRI:

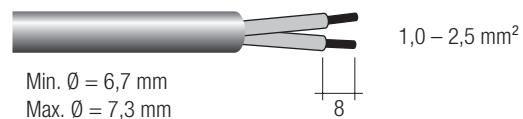

SEC:

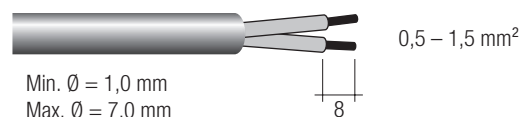

Insulation and electric strength testing of luminaires

Electronic devices can be damaged by high voltage. This has to be considered during the routine testing of the luminaires in production.

According to IEC 60598-1 Annex Q (informative only!) or ENEC 303-Annex A, each luminaire should be submitted to an insulation test with 500 V_{DC} for 1 second. This test voltage should be connected between the interconnected phase and neutral terminals and the earth terminal.

The insulation resistance must be at least 2 MΩ.

As an alternative, IEC 60598-1 Annex Q describes a test of the electrical strength with 1500 V_{AC} (or 1.414 x 1500 V_{DC}). To avoid damage to the electronic devices this test must not be conducted.

Maximum number of switching cycles

All LED Driver are tested with 50,000 switching cycles.
The actually achieved number of switching cycles is significantly higher.

Additional information

Additional technical information at www.tridonic.com → Technical Data

Guarantee conditions at www.tridonic.com → Services

No warranty if device was opened.