

Module TW DLE G2 60mm 3000lm 927-965

DLE modules

Product description

- Tunable White module for Downlights with adjustable colour temperature from 2,700 to 6,500 K at constant luminous flux
- Long lifetime of 50,000 h and 5-year system guarantee

Optical properties

- LED module for Downlight applications with 2,000 or 3,000 lm
- Useful luminous flux 2,070 lm at Irated and tp = 25 °C
- Efficacy of the LED module 127 lm/W at Irated and tp = 25 °C
- High colour rendering index CRI > 90
- Small colour tolerance MacAdam 3

Mechanical properties

- Module dimension 81.5 x 81.5 mm
- Simple installation (e.g. screws)

Typical applications

- Downlight for retail and corridor applications
- Tunable white application



Standards, page 3

Colour temperatures and tolerances, page 6





Module TW DLE G2 60mm 3000lm 927-965
DLE modules

Technical data

Beam characteristic	120°
Ambient temperature range	-25 ... +55 °C
tp rated	65 °C
tc	95 °C
Irated	400 mA
Imax	700 mA
Max. permissible LF current ripple	770 mA
Max. permissible peak current	2,000 mA / max. 10 ms
Max. working voltage for insulation SELV ^①	< 60 V
Insulation test voltage	0.5 kV
ESD classification	severity level 4
Risk group (IEC 62471)	RG1
Classification acc. to IEC 62031	Built-in
Type of protection	IP00
Lumen maintenance L70B50	up to 50,000 h
Guarantee	5 years

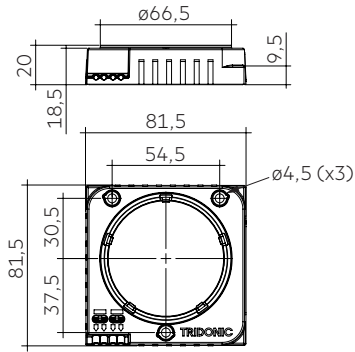

Ordering data

Type	Article number	Colour temperature	Packaging, carton	Weight per pc.
TW DLE G2 60mm 3000lm 927-965	89603439	2,700 / 6,500 K	10 pc(s).	0.057 kg

Specific technical data

Type	Channel	Photometric code	Useful luminous flux at tp = 25 °C ^②	Expected luminous flux at tp rated ^③	Typ. forward current	Min. forward voltage at tp = 65 °C	Max. forward voltage at tp = 25 °C	Power consumption Pon at tp = 25 °C ^④	Efficacy of the module at tp = 25 °C	Expected efficacy of the module at tp rated	Colour rendering index CRI
TW DLE G2 60mm 3000lm 927-965	WW	927/349	2,070 lm	1,941 lm	400 mA	38.0 V	42.1 V	16.3 W	127 lm/W	123 lm/W	>90
	CW	965/349	-	2,189 lm	400 mA	39.0 V	43.1 V	-	-	135 lm/W	>90
	WW	927/349	-	2,836 lm	600 mA	40.0 V	44.1 V	-	-	114 lm/W	>90
	CW	965/349	-	3,005 lm	600 mA	41.3 V	45.5 V	-	-	117 lm/W	>90

^① Mounted with M4 screw.

^② Tolerance of useful light flux - 0 % / + 15 %. Measurement uncertainty ± 10 %.

^③ Tolerance of expected light flux - 0 % / + 15 %. Measurement uncertainty ± 10 %. Based on calculation.

^④ Tolerance of power consumption Pon ± 10 %. Measurement uncertainty ± 5 %.

1. Standards

EN 61000-4-2
EN 61547
EN 62031
EN 62471
EN 62778

1.1 Photometric code

Key for photometric code, e. g. 930 / 349

1 st digit	2 nd + 3 rd digit	4 th digit	5 th digit	6 th digit	
Code	CRI	Colour temperature in Kelvin x 100	MacAdam initial	MacAdam after 25% of the lifetime (max.6000h)	
7	70 – 79			Code	Luminous flux
8	80 – 89			7	≥ 70 %
9	≥90			8	≥ 80 %
			9	≥ 90 %	

1.2 Energy classification

Type	Colour temperature	Forward current	Energy classification	Energy consumption
TW DLE G2 60mm 3000lm 927-965	2,700 K	400 mA	E	17 kWh / 1,000 h

Energy label and further information at www.tridonic.com in the certificates tab of the corresponding product page and at the EPREL data base <https://eprel.ec.europa.eu/>

2. Thermal details

2.1 tc point, ambient temperature and lifetime

The temperature at tp reference point is crucial for the light output and lifetime of a LED product.

For DLE a tp temperature of 65°C has to be complied in order to achieve an optimum between heat sink requirements, light output and lifetime.

Compliance with the maximum permissible reference temperature at the tc point must be checked under operating conditions in a thermally stable state. The maximum value must be determined under worst-case conditions for the relevant application.

The tc and tp temperature of LED modules from Tridonic are measured at the same reference point.

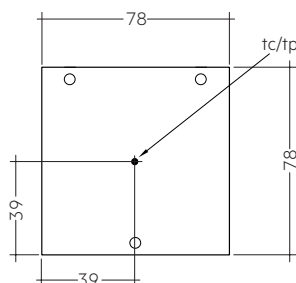

2.2 Storage and humidity

Storage temperature	-40 ... +80 °C
---------------------	----------------

Operation only in non condensing environment.
Humidity during processing of the module should be between 30 to 70 %.

2.3 Thermal design and heat sink

The rated life of LED products depends to a large extent on the temperature. If the permissible temperature limits are exceeded, the life of the DLE will be strongly reduced or even destroyed.

2.4 Thermal design and heat sink

The rated life of LED products depends to a large extent on the temperature. If the permissible temperature limits are exceeded, the life of the DLE will be greatly reduced or the DLE may be destroyed.

2.5 Heat sink values

ta	tp	Forward current	R _{th, hs-a}	Cooling area
25°C	65°C	400 mA	4.14 K/W	161 cm ²
25°C	65°C	600 mA	2.47 K/W	270 cm ²
35°C	65°C	400 mA	3.10 K/W	215 cm ²
35°C	65°C	600 mA	1.85 K/W	361 cm ²
40°C	65°C	400 mA	2.58 K/W	258 cm ²
40°C	65°C	600 mA	1.54 K/W	433 cm ²
45°C	65°C	400 mA	2.07 K/W	323 cm ²
45°C	65°C	600 mA	1.23 K/W	543 cm ²
50°C	65°C	400 mA	1.55 K/W	431 cm ²
50°C	65°C	600 mA	0.92 K/W	725 cm ²
55°C	65°C	400 mA	1.03 K/W	648 cm ²
55°C	65°C	600 mA	0.61 K/W	1,092 cm ²
60°C	65°C	400 mA	0.51 K/W	1,305 cm ²
60°C	65°C	600 mA	0.30 K/W	2,210 cm ²

Notes

The actual cooling can differ because of the material, the structural shape, outside influences and the installation situation. A thermal connection between DLE and heat sink with heat-conducting paste or heat conducting adhesive film is absolutely necessary.

Additionally the DLE has to be fixed on the heat sink with M4 screws to optimise the thermal connection.

Use of thermal interface material with thermal conductivity of $\lambda > 1$ W/mK and layer thickness of interface material with max. 50 μ m or a similar interface material where the quotient of layer thickness and thermal conductivity $b < 50$ μ mmK/W.

3. Installation / wiring

3.1 Electrical supply/choice of LED driver

DLE modules must be operated with SELV LED drivers.



DLE modules are basic insulated up to 60 V SELV against ground and can be mounted directly on earthed metal parts of the luminaire. If the max. output voltage of the LED driver (also against earth) is above 60 V SELV, an additional insulation between LED module and heat sink is required (for example by insulated thermal pads) or by a suitable luminaire construction.

At voltages > 60 V an additional protection against direct touch (test finger) to the light emitting side of the module has to be guaranteed. This is typically achieved by means of a non removable light distributor over the module.

3.2 Wiring examples

Wiring diagram for switchDIM and colourSWITCH for DLE premium

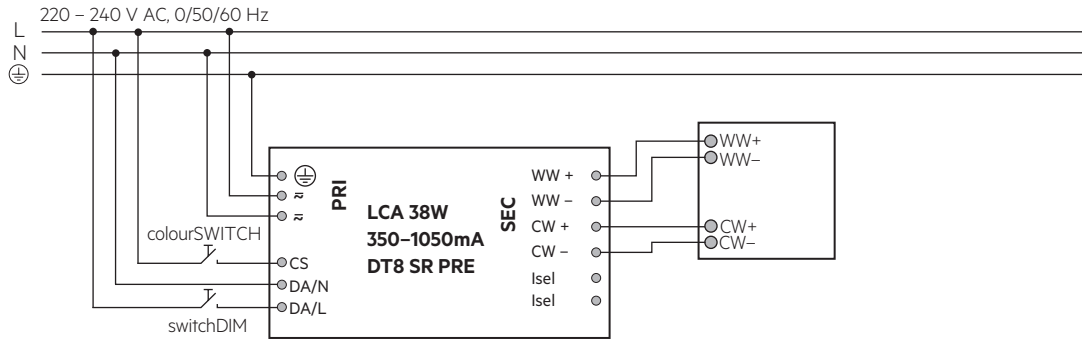

Wiring diagram for DALI for DLE premium

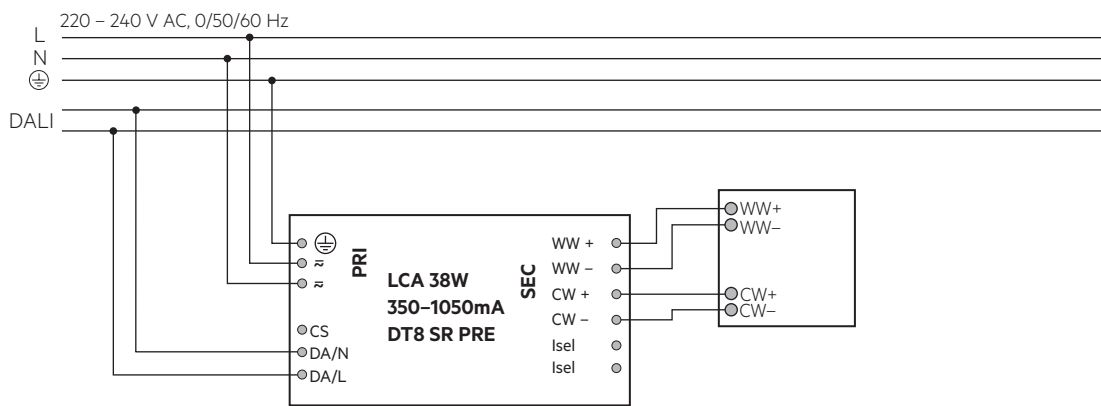

Wiring diagram for emergency

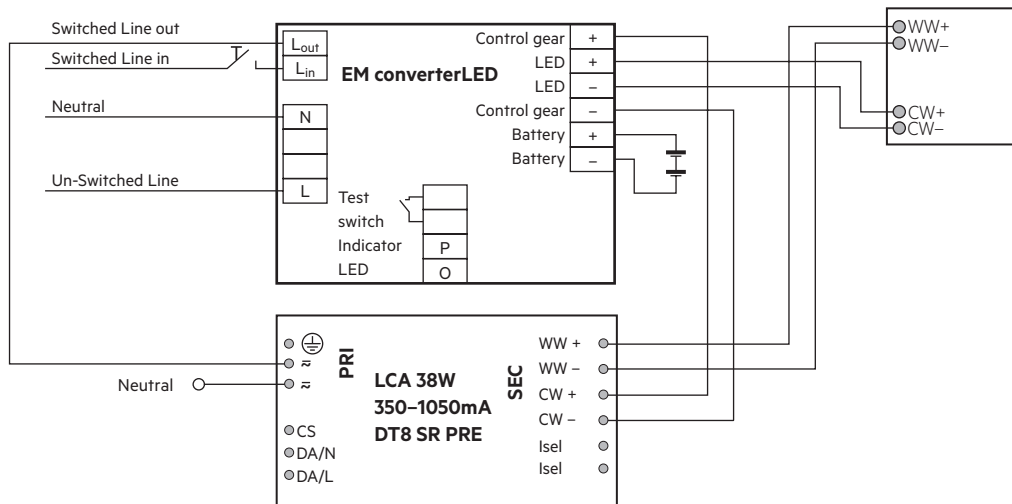

3.3 Wiring type and cross section

The wiring can be solid cable with a cross section of 0.2 to 0.75 mm².
For the push-wire connection you have to strip the insulation (7–9 mm).

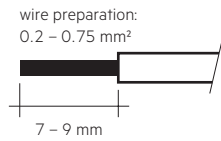

Inserting stranded wires / removing wires by lightly pressing on the push button.

3.4 Mounting instruction



None of the components of the DLE (substrate, LED, electronic components etc.) may be exposed to tensile or compressive stresses.

Max. torque for fixing: 0.5 Nm.

The LED modules are mounted with 3 screws per module. In order not to damage the modules only rounded head screws and an additional plastic flat washer should be used.



Chemical substance may harm the LED module. Chemical reactions could lead to colour shift, reduced luminous flux or a total failure of the module caused by corrosion of electrical connections.

Materials which are used in LED applications (e.g. sealings, adhesives) must not produce dissolver gas. They must not be condensation curing based, acetate curing based or contain sulfur, chlorine or phthalate.

Avoid corrosive atmosphere during usage and storage.

3.5 EOS/ESD safety guidelines



The device / module contains components that are sensitive to electrostatic discharge and may only be installed in the factory and on site if appropriate EOS/ESD protection measures have been taken. No special measures need be taken for devices/modules with enclosed casings (contact with the pc board not possible), just normal installation practice. Please note the requirements set out in the document EOS / ESD guidelines (Guideline_EOS_ESD.pdf) at: <http://www.tridonic.com/esd-protection>

4. Lifetime

4.1 Lifetime, lumen maintenance and failure rate

The light output of an LED module decreases over the lifetime, this is characterized with the L value.

L70 means that the LED module will have 70 % of its initial luminous flux after the stated operating time. This value is always related to the number of operation hours and therefore defines the lifetime of an LED module.

As the L value is a statistical value the lumen maintenance may vary over the delivered LED modules.

The B value defines the amount of modules which are below the specific L value, e.g. L70B10 means 10 % of the LED modules are below 70 % of the initial luminous flux, respectively 90 % will be above 70 % of the initial value.

In addition the percentage of failed modules (fatal failure) is characterized by the C value.

The F value is the combination of the B and C value. That means for F degradation and complete failures are considered, e.g. L70F10 means 10 % of the LED modules may fail or be below 70 % of the initial luminous flux.

Lifetime declarations are informative and represent no warranty claim.

4.2 Lumen maintenance for DLE

Forward current	tp temperature	L90 / F10	L90 / F50	L80 / F10	L80 / F50	L70 / F10	L70 / F50
600 mA	45 °C	>50,000 h	>50,000 h	>50,000 h	>50,000 h	>50,000 h	>50,000 h
	50 °C	46,000 h	>50,000 h	>50,000 h	>50,000 h	>50,000 h	>50,000 h
	55 °C	40,000 h	>50,000 h	>50,000 h	>50,000 h	>50,000 h	>50,000 h
	60 °C	35,000 h	>50,000 h	>50,000 h	>50,000 h	>50,000 h	>50,000 h
	65 °C	30,000 h	48,000 h	>50,000 h	>50,000 h	>50,000 h	>50,000 h
	70 °C	26,000 h	41,000 h	>50,000 h	>50,000 h	>50,000 h	>50,000 h
	75 °C	22,000 h	35,000 h	>50,000 h	>50,000 h	>50,000 h	>50,000 h
	80 °C	19,000 h	30,000 h	45,000 h	>50,000 h	>50,000 h	>50,000 h
700 mA	85 °C	17,000 h	25,000 h	39,000 h	>50,000 h	>50,000 h	>50,000 h
	45 °C	>50,000 h	>50,000 h	>50,000 h	>50,000 h	>50,000 h	>50,000 h
	50 °C	45,000 h	>50,000 h	>50,000 h	>50,000 h	>50,000 h	>50,000 h
	55 °C	39,000 h	>50,000 h	>50,000 h	>50,000 h	>50,000 h	>50,000 h
	60 °C	34,000 h	>50,000 h	>50,000 h	>50,000 h	>50,000 h	>50,000 h
	65 °C	29,000 h	46,000 h	>50,000 h	>50,000 h	>50,000 h	>50,000 h
	70 °C	25,000 h	40,000 h	>50,000 h	>50,000 h	>50,000 h	>50,000 h
	75 °C	22,000 h	34,000 h	>50,000 h	>50,000 h	>50,000 h	>50,000 h
80 °C	19,000 h	29,000 h	44,000 h	>50,000 h	>50,000 h	>50,000 h	
85 °C	17,000 h	25,000 h	38,000 h	>50,000 h	>50,000 h	>50,000 h	

5. Photometric characteristics

5.1 Coordinates and tolerances according to CIE 1931

The specified colour coordinates are integral measured by a current impulse of 750 mA / 2,700 K and 600 mA / 6,500 K and a duration of 100 ms. The ambient temperature of the measurement is $t_a = 25^\circ\text{C}$. The measurement tolerance of the colour coordinates are ± 0.01 .

2,700 K

	x0	y0
Centre	0.4621	0.4113

MacAdam ellipse: 3SDCM

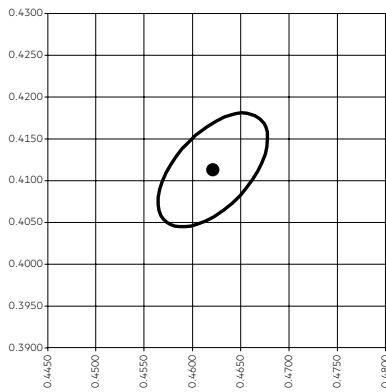

6,500 K

	x0	y0
Centre	0.3186	0.3340

MacAdam ellipse: 3SDCM

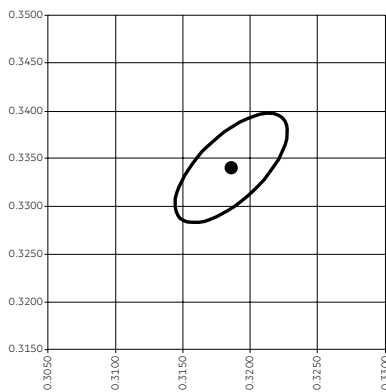

Colour spectrum at different colour temperatures

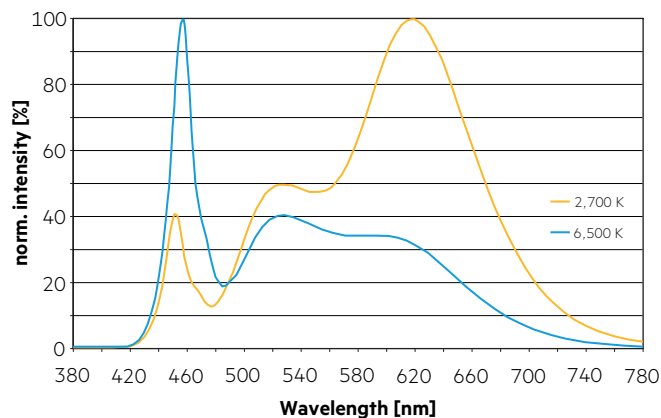

5.2 Light distribution

The optical design of the DLE product line ensures optimum homogeneity for the light distribution.



The colour temperature is measured integral over the complete module.

To ensure an ideal mixture of colours and a homogeneous light distribution a suitable optic (e. g. PMMA diffuser) and a sufficient spacing between module and optic (typ. 6 cm) should be used.

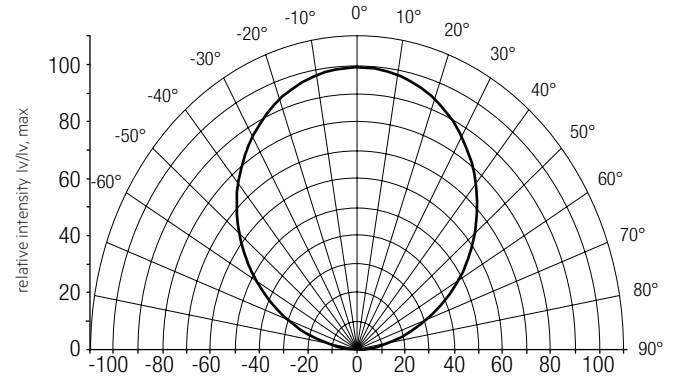

For further information see Design-in Guide, 3D data and photometric data on www.tridonic.com or on request.

5.3 Relative luminous flux vs. operating temperature

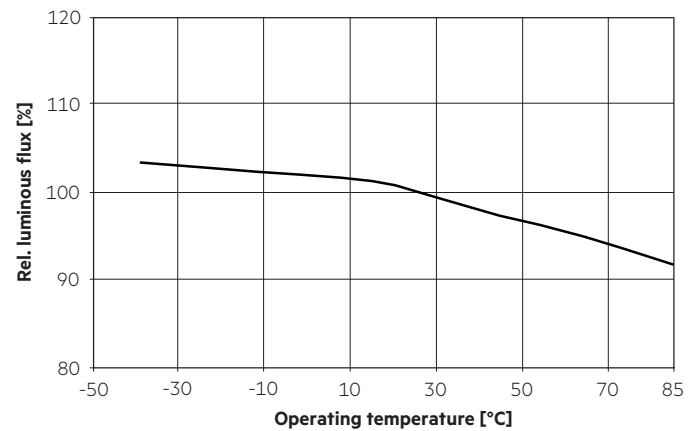

The diagrams are based on statistic values.

6. Miscellaneous

6.1 Additional information

Additional technical information Design-in Guide, 3D data, photometric data and Guarantee conditions at www.tridonic.com